



# EARTHSTONE

---

## WOOD-FIRE OVENS

### PRE-ASSEMBLED INSTALLATION INSTRUCTIONS FOR PACB SERIES COAL FIRED OVENS



Intertek



Intertek

OVENS MANUFACTURED BY:

EARTHSTONE OVENS-6717 SAN FERNANDO RD GLENDALE CA 91201

TELEPHONE: 800-840-4915 818-553-1134 FAX: 818-553-1133

[www.earthstoneovens.com](http://www.earthstoneovens.com) e-mail: earthstone@earthlink.net

**A MAJOR CAUSE OF OVEN RELATED FIRES IS FAILURE TO MAINTAIN  
REQUIRED CLEARANCES (AIR SPACES) TO COMBUSTIBLE MATERIALS. IT IS  
OF UTMOST IMPORTANCE THAT THIS OVEN BE INSTALLED ONLY IN  
ACCORDANCE WITH THESE INSTRUCTIONS**

11/1/2009

**Coal Fired Pre-Assembled installation instructions.**

<b><u>Table of contents</u></b>	<b>Page</b>
<u>Instructions for moving and lifting oven</u>	
Parts list	1
Installation procedures written portion	3
Required clearances and air gaps	4-5
Exhausting	6-9
Cross air vent diagram	10
Fuel Storage	10

# INSTRUCTIONS FOR LIFTING AND MOVING OVEN

**ATTENTION:** Only proper heavy lifting machinery and handling equipment should be used for unloading, moving and installing the oven. This duty should be performed by professionals trained in this kind of work. Improper handling of the equipment could result in damaging the oven or personal injury.

## 1- USING A FORKLIFT

Determine if forklift capacity is sufficient to lift oven. (6000 lb for models 90 and 110, and 8000 lb for models 130 and 160)

Prior to lifting, make sure forks are long enough to reach both horizontal steel tubes on underside of oven (Without touching oven shell). Approach oven from front entrance side or rear side. Keep forklift straight. Carefully place forks through inside of tube steel supports legs and position under horizontal tube steel members. Slowly lift and move oven as needed. (See dia. A)

## 2- USING A PALLET JACK

Determine if pallet jack capacity is sufficient to lift oven. (4500 lb for models 90, 110, 130 and 6000 lb for model 160)

Prior to lifting, make sure pallet jack is long enough to reach both horizontal angles at lower end of steel tube support legs. Place pallet jack between tube steel support legs under horizontal angles. (See dia. B) Carefully lift oven and move slowly.

**CAUTION:** OVEN IS TOP HEAVY MOVE WITH CARE.

## 3- INSTALLING OVEN

Slowly lower oven into proper location. Oven should be set on a level floor. Shim as necessary to assure that oven is level. Remove horizontal front angle when oven is in place. Insert ramset red heads, min. of 3 inches in length, through base plates. (See fig 17-A pg. 7 in installation instructions)

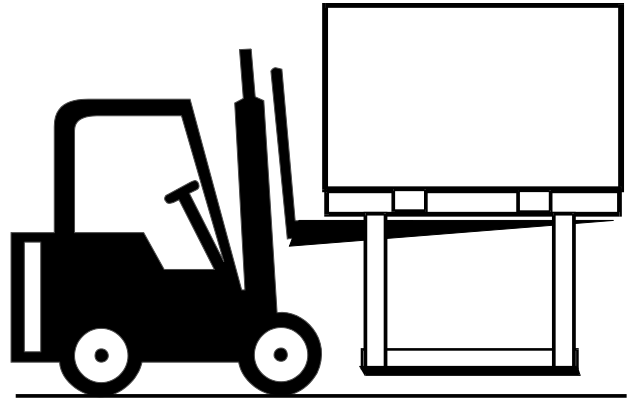

DIA. A

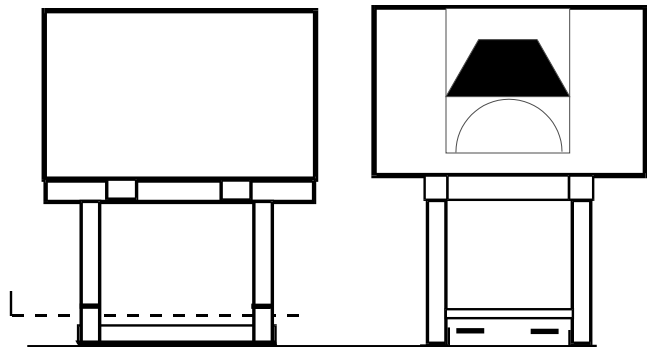

DIA. B

## **LIST OF SUPPLIED ITEMS**

### **OVEN**

### **ADDITIONAL ITEMS**

- **CAST ALUMINUM DOOR**
- **DIAL TEMPERATURE GAUGE**
- **COAL GRATE**
- **COMBUSTION AIR INTAKE FAN**
- **ASH DISPOSAL BIN**

## PRE-ASSEMBLED INSTALLATION INSTRUCTION GUIDE

### READ ALL INSTRUCTIONS CAREFULLY BEFORE INSTALLING AND USING THE APPLIANCE.

If this oven is not properly installed, a fire may result. To reduce the risk of fire, follow the installation instructions. Please read this entire manual before you install the oven. Failure to follow instructions may result in property damage, bodily injury, or even death.

The installer should contact the local building or fire officials concerning any installation restrictions and the need for inspection(s) of the oven and venting applications before beginning installation.

Obtain the necessary permit to construct. In most areas this will include a permit to construct the oven and a permit for the exhaust system. Sometimes an electrical permit is also necessary for connecting the exhaust fan. All construction must comply with local building codes. There are some portions of these instructions which are more restrictive than the building codes. Whichever is most restrictive must be followed.

**The diagram below indicates the minimum floor space required.**  
(ALL DIMENSIONS ARE TO OUTSIDE FACE OF STEEL ENCLOSURE)

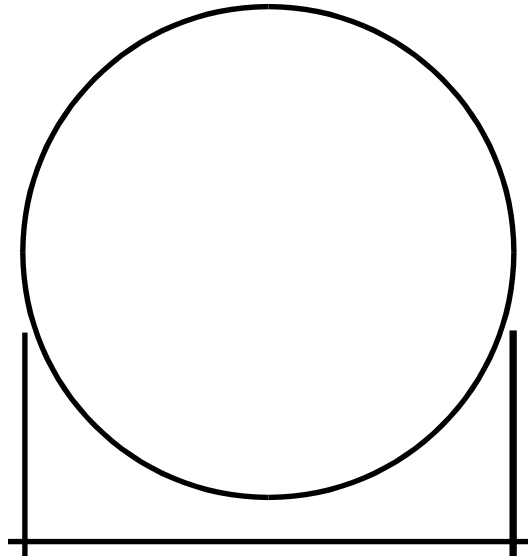

### OUTSIDE DIMENSIONS

MODEL 110-PACB 58" DIA - MODEL 130-PACB 70" DIA - MODEL 160-PACB 86" DIA

### IMPORTANT REMINDER

After reading this installation guide it is important to determine which venting application method will be used.

Most cities accept the U.L. listed chimney installation (direct venting) however a few cities will require the use of a Type I grease hood over the oven opening. Check with your local building department to determine which is acceptable.

To maintain the ETL listing of the oven the venting application needs to be installed in accordance with the guidelines specified in this installation instruction guide.

### SAVE THESE INSTRUCTIONS

## A. INSTALLATION PROCEDURES

1. Mark an outline on the floor of the location desired. This is to assure that you have adequate space. Refer to Fig. 1, pg. 6.
2. Check that there is adequate clearance at the ceiling for the hood. There must be a minimum of 3 inches of clearance between the top of the hood and/or oven and the surface of the drywall above. If direct venting is used then 83 inches will be sufficient (Refer to Fig. 2 & 3 pg. 4) A height of 105 inches is needed for a basic installation (Including hood).
3. Check that there is a minimum clearance of 1 inch to any adjacent sidewall construction containing combustibles. Any adjacent combustible sidewalls which projects beyond the front of the oven opening must be a minimum of 48 inches, measured from the side of the oven opening closest to the wall to the surface of the wall. (Refer to Fig. 4, pg. 4). If the distance is less than 48 inches a wall shield must be mounted on the wall. Refer to the U.L. listed wall shield installation instructions for the allowable clearance reduction.

Any adjacent combustible floor which projects in front of the oven opening must be a minimum of 30 inches away from each side of the door opening and 36 inch from the front of the door opening.

### **WARNING: DO NOT PACK REQUIRED AIR SPACES WITH INSULATION OR OTHER MATERIALS**

A minimum of 3 inches must be maintained between any combustibles and the top of the metal covering over the oven enclosure. (Refer to Fig 2 & 3 pg. 4.)

4. Once the oven is in the desired position, drill holes for the anchor bolts (Min 4 inches deep) using the base plates as a guide. Insert anchors to fasten oven base plates to concrete floor. Use ½" Dia. Anchors, 3 anchors each side. (Coat with Simpson's Epoxy)

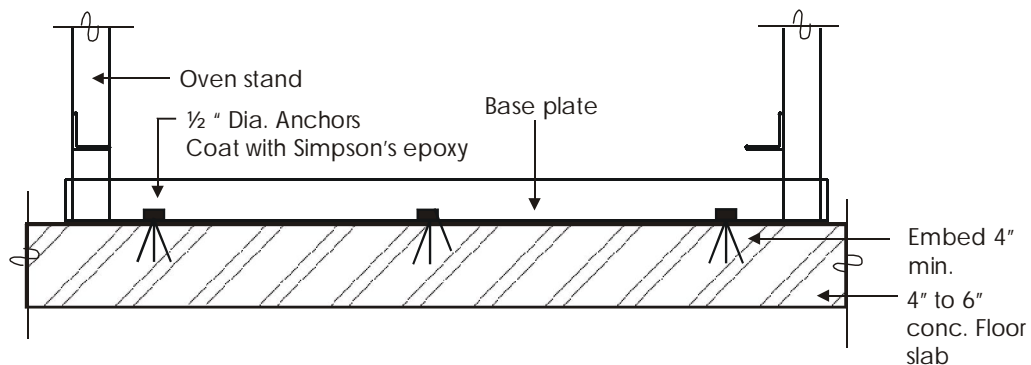

5. The outside surface of the oven enclosure may be faced with non-combustible facing material if desired. This might include but not limited to: Brick, Ceramic tiles, Stainless steel, Marble or any other decorative metals. **DO NOT FACE WITH COMBUSTIBLE MATERIALS OR USE COMBUSTIBLE ADHESIVES. ALLOW FOR ACCESS TO TOP AND BOTTOM OF THE OVEN FOR SERVICING AND REMOVAL OF ASH BIN. COAL FAN SHOULD NOT BE BLOCKED BY ANY WALLS, FACADES OR OBJECTS. (SEE PG 5)**

**NOTE: FOR HEALTH DEPARTMENT REQUIREMENTS ANY 1-INCH AIR GAP ADJACENT TO A COMBUSTIBLE WALL MUST BE SEALED WITH A NON COMBUSTIBLE STRIP. i.e. ALUMINUM, STAINLESS STEEL OF TILE.**

ALL CLEARANCES SPECIFIED ARE THE MINIMUM REQUIRED AIR SPACES

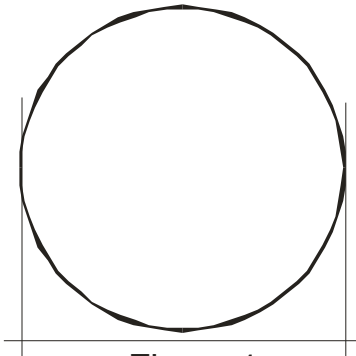

Figure 1  
OUTSIDE DIAMETER  
MODEL 130-PACB - 70"  
MODEL 160-PACB - 86"

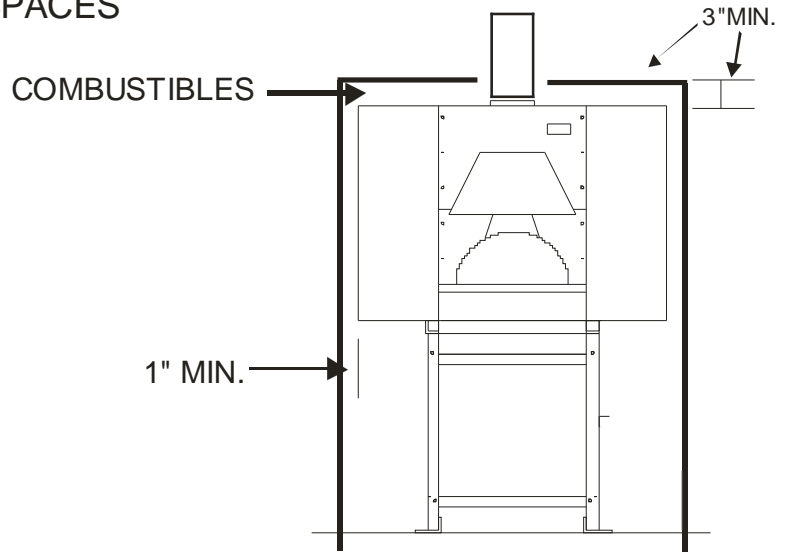

Figure 3  
U.M.C. & N.F.P.A.

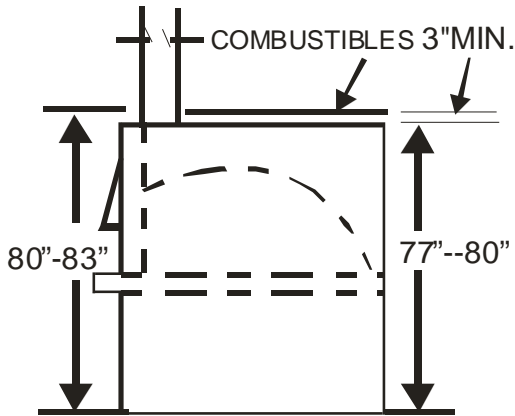

Figure 2 - Direct Venting  
U.M.C. & N.F.P.A.

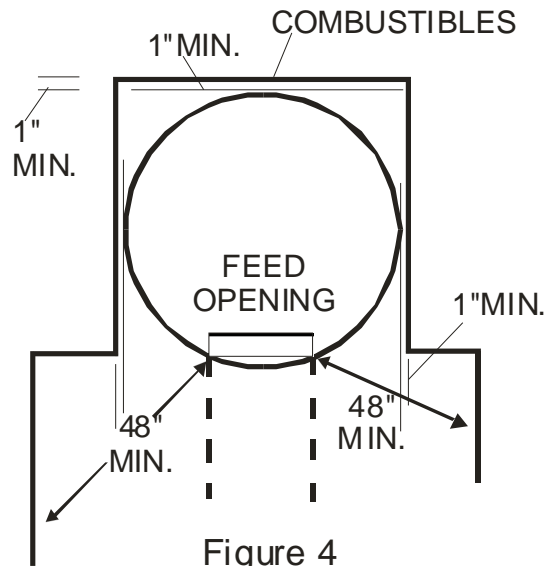

Figure 4

Any adjacent combustible floor which projects in front of the oven opening must be a minimum of 30 inches away from each side of the door opening and 36 inches from the front of the door opening.

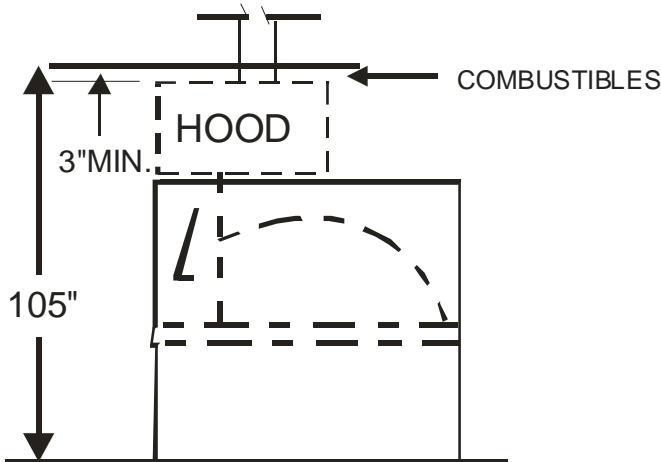
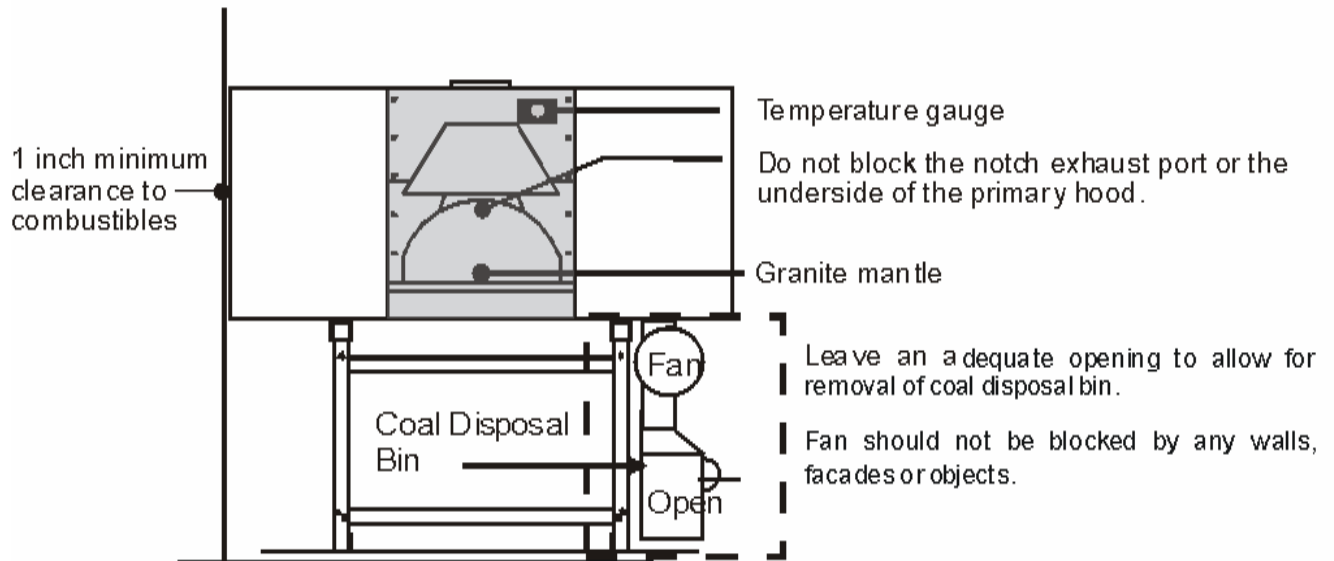
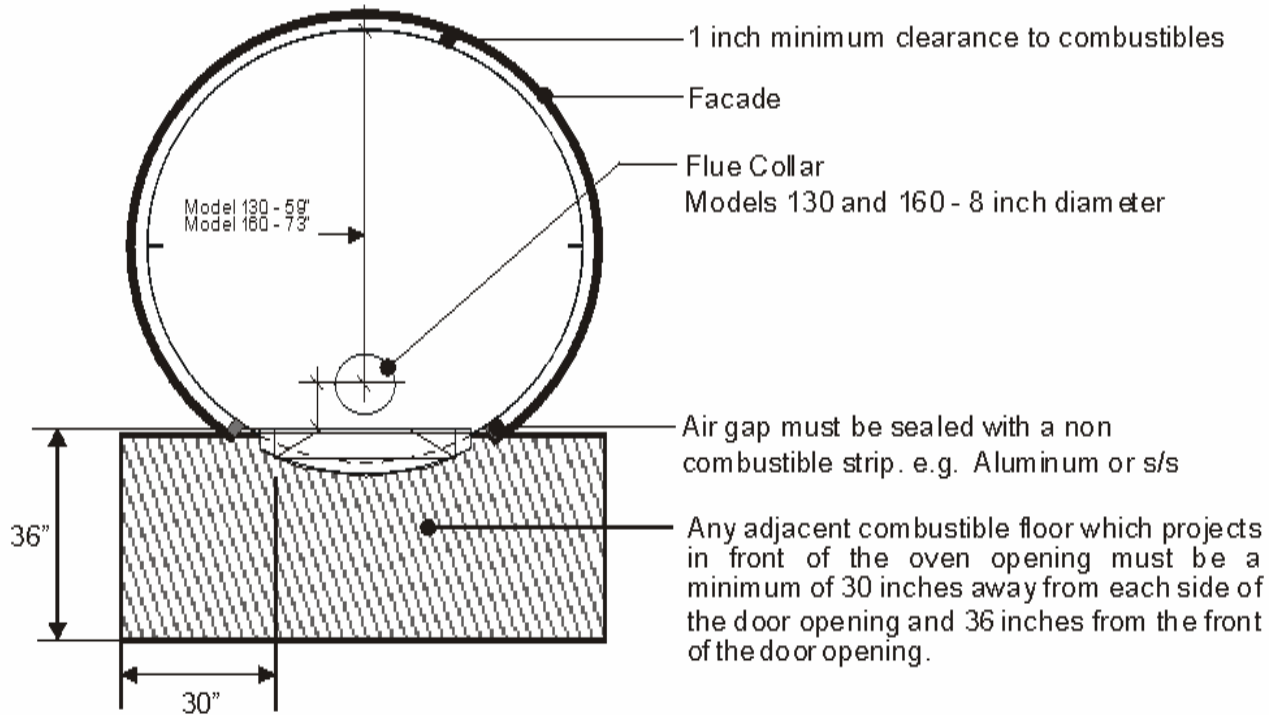



Figure 2 - Exhaust Hood  
U.M.C. & N.F.P.A.

**WARNING: DO NOT PACK REQUIRED AIR SPACES WITH INSULATION OR OTHER MATERIALS.**

## CLEARANCE INFORMATION FOR FACADES



 If this area is to be covered with a facade it must be of a non-combustible material.

## B. VENTING APPLICATIONS

### DIRECT VENTING

#### U.L. LISTED GREASE DUCT/BUILDING HEATING APPLIANCE CHIMNEY INSTALLATION

**IT IS NEVER APPROPRIATE TO USE "CLASS A" OR "B VENT" IN ANY PART OF THE EXHAUST SYSTEM. EXHAUST SYSTEMS SERVING SOLID-FUEL EQUIPMENT MAY NOT BE COMBINED WITH EXHAUST SYSTEMS SERVING OTHER (NON-SOLID FUEL) COOKING EQUIPMENT**

1. A U.L. listed Grease Duct/Building Heating Appliance Chimney may be connected to the opening in the primary hood of the oven. Refer to Fig. 18, pg. 7. For specific installation requirements refer to Selkirk Metalbestos Model PS and IPS Grease Duct Installation Instructions or Metal-Fab IPIC Installation Instructions.
2. A field-built duct, constructed and installed to the specifications of a grease duct, as detailed in NFPA 96 or the International Mechanical Code, may also be used.

**Volume:** 150-200 CFM

**Models:** Metal-Fab IPIC or Value G (metal-fabcommercial.com)  
or Selkirk Metalbestos Model IPS (selkirkcorp.com)

**Important: Chases should be made of non-combustible materials.**

# DIRECT VENTING

FOR ORDERING PARTS MENTIONED ON THIS PAGE CONTACT EARTHSTONE OR YOUR SUPPLIER. Tel: 800-840-4915- 818-553-1134

**MODELS 90 & 110 USE 6 INCH INSIDE DIAMETER GREASE DUCT**  
**MODELS 130 & 160 USE 8 INCH INSIDE DIAMETER GREASE DUCT**

500 CFM EXHAUST FAN AND CURB POWER VENTILATOR FOR RESTAURANT EXHAUST APPLIANCES. RATED FOR 300 DEG. MODELS: CENTRAL BLOWER RE-12 OR EXHAUSTO GSV-012. CALL EARTHSTONE FOR DETAILS 800-840-4915 - 818-553-1134

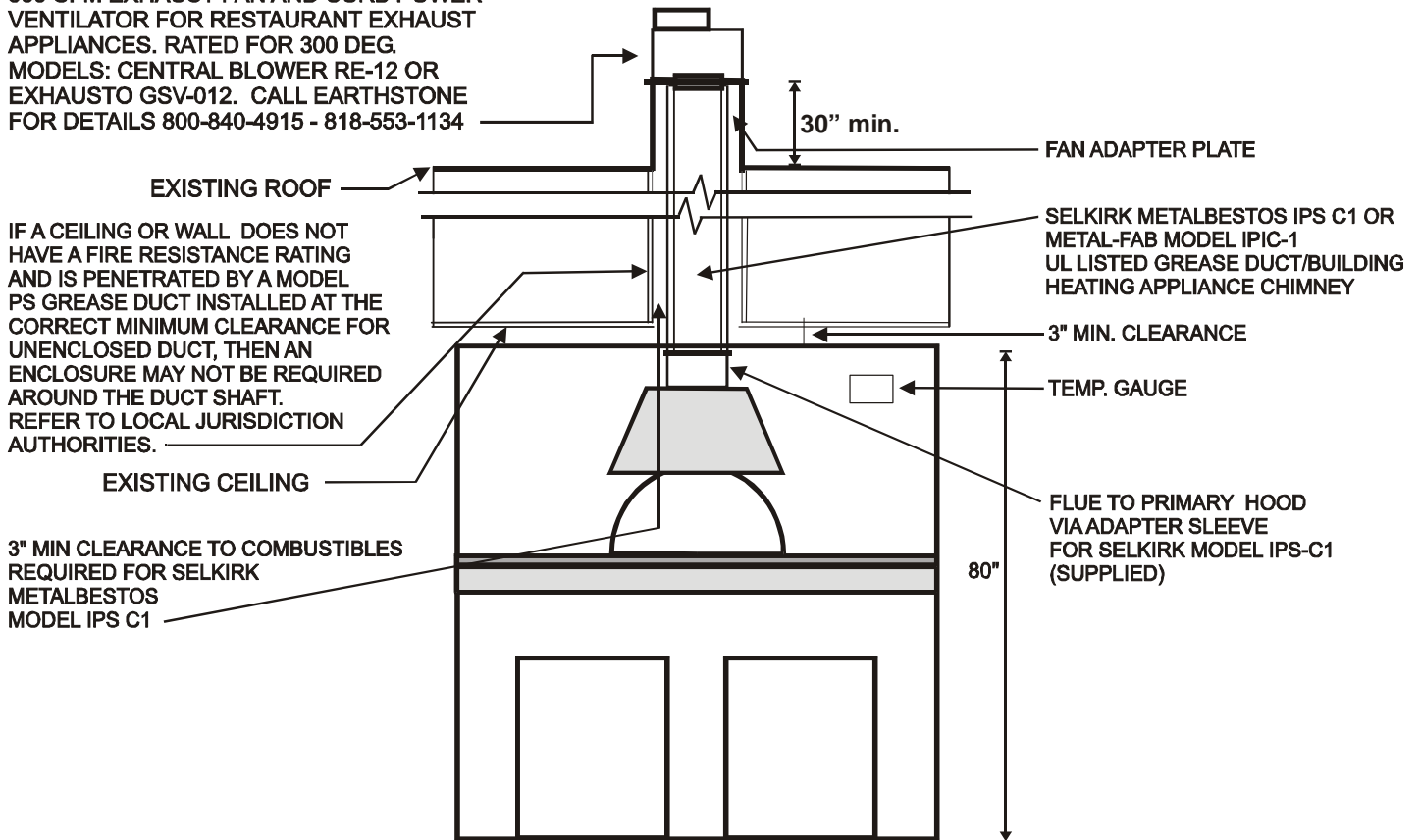

**FIGURE 18**

GREASE DUCT HEATING APPLIANCE CHIMNEY ATTACHED TO PRIMARY HOOD

THIS DIAGRAM GENERALLY DEPICTS THE INSTALLATION REQUIRED TO MAINTAIN THE U.L. LISTING OF THE OVEN FOR THIS TYPE OF VENTING APPLICATION.

FOR SPECIFIC INSTALLATION REQUIREMENTS REFER TO SELKIRK METALBESTOS MODEL IPS GREASE DUCT INSTALLATION 8. MODEL PS AND IPS GREASE DUCT COMPLIES WITH NFPA, SBCCI, ICBO AND BOCA WHEN PROPERLY INSTALLED PER ITS INSTALLATION INSTRUCTIONS.

CONTACT LOCAL AUTHORITY HAVING JURISDICTION REGARDING FIRE RATED DUCT SHAFT.

NOTE: OTHER U.L. LISTED SYSTEMS MAY BE SUBSTITUTED FOR THE METALBESTOS SYSTEM DEPICTED IN THIS DIAGRAM. TO MAINTAIN THE U.L. LISTING OF THE OVEN THE SYSTEM MUST BE A U.L. LISTED GREASE DUCT WHICH IS ALSO A U.L. LISTED BUILDING HEATING APPLIANCE CHIMNEY INSTALLED IN ACCORDANCE WITH THE MANUFACTURER'S GREASE DUCT INSTALLATION INSTRUCTIONS.

## TYPE-I EXHAUST HOOD-Installed per NFPA 96

**TYPE-I EXHAUST HOOD-Installed per NFPA 96, standard for ventilation control and fire protection of commercial cooking operations. (For commercial applications only)**

1. If required, a Type 1 hood must be placed above the cooking opening and set on the top of the oven. A height of 105 inches is needed for a basic installation (Including hood, see diagram below). The minimum exhaust hood dimensions are 40 in. wide, 37 in. deep and 22 inches high for models 130 and 160. Refer to Fig. 19, PG. 9.  
**Duct Velocity 1500-2500 FPM - Volume: 800-1000 CFM**
2. The grease filters must be positioned at the rear of the exhaust hood and must be of the steel baffle type (Mesh type grease filters must not be used).
3. The front of the exhaust hood is to set forward 10 inches from the front of the oven face. The face of the filter must be a minimum of 42 inches from the oven heat per the Uniform Mechanical Codes. (UMC) or 48 inches per NFPA 96. When the exhaust hood is fabricated, it is recommended that the bottom portion which is set on the oven(sheet metal lid) be closed for ease of cleaning. Refer to Fig 19 pg. 9.
4. The sides of the exhaust hood must extend a minimum of 6 inches to either side of the oven door opening.
5. There must be a minimum of 3 inches of clearance between the hood and any combustible surface.
6. The exhaust duct is to be constructed as vertical as possible, free of offsets and horizontal runs. If a horizontal run is needed then refer to the Grease Duct/Building Heating Appliance installation section.

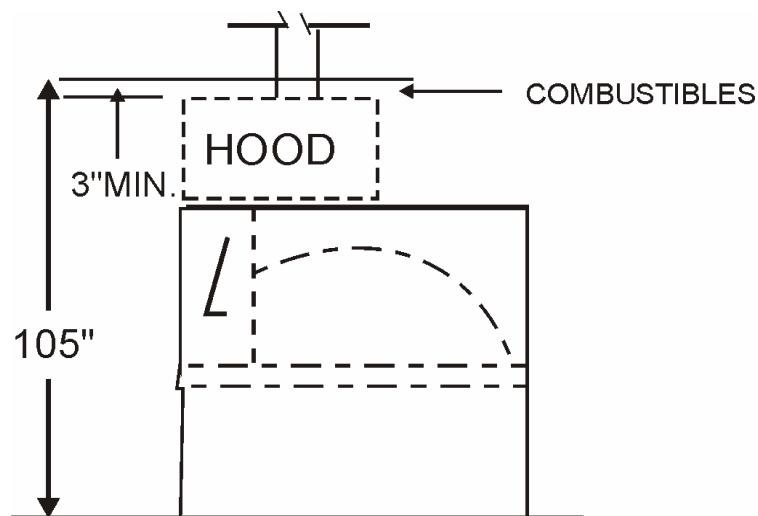

Exhaust Hood  
U.M.C. & N.F.P.A.

## Type-I Exhaust Hood Installed per NFPA 96

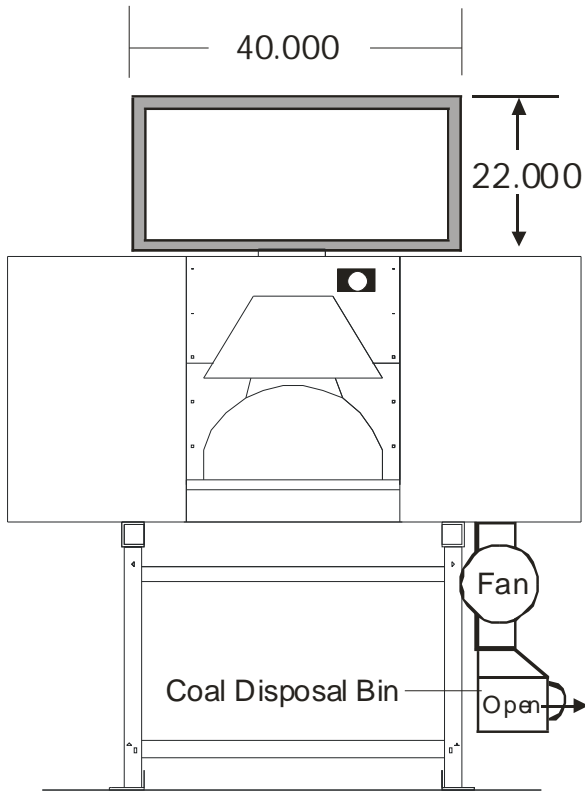

**\*\*IT IS NEVER APPROPRIATE TO USE "CLASS A" OR "B VENT" IN ANY PART OF THE EXHAUST SYSTEM EXHAUST SYSTEMS SERVING SOLID-FUEL EQUIPMENT MAY NOT BE COMBINED WITH EXHAUST SYSTEMS SERVING OTHER (NON-SOLID FUEL) COOKING EQUIPMENT**

**Grease filters must be placed at the rear of the hood and must be of the steel baffle type (No mesh filters).**

**Front of hood must be at least 10 inches from the front of the oven face.**

**Face of the filter must be 42 inches from oven hearth per UMC or 48 inches per NFPA 96**

**Sides of the hood must extend a min. of 6 inches to either side of the oven door opening.**

**3 inch min. clearance between the hood and any combustible material.**

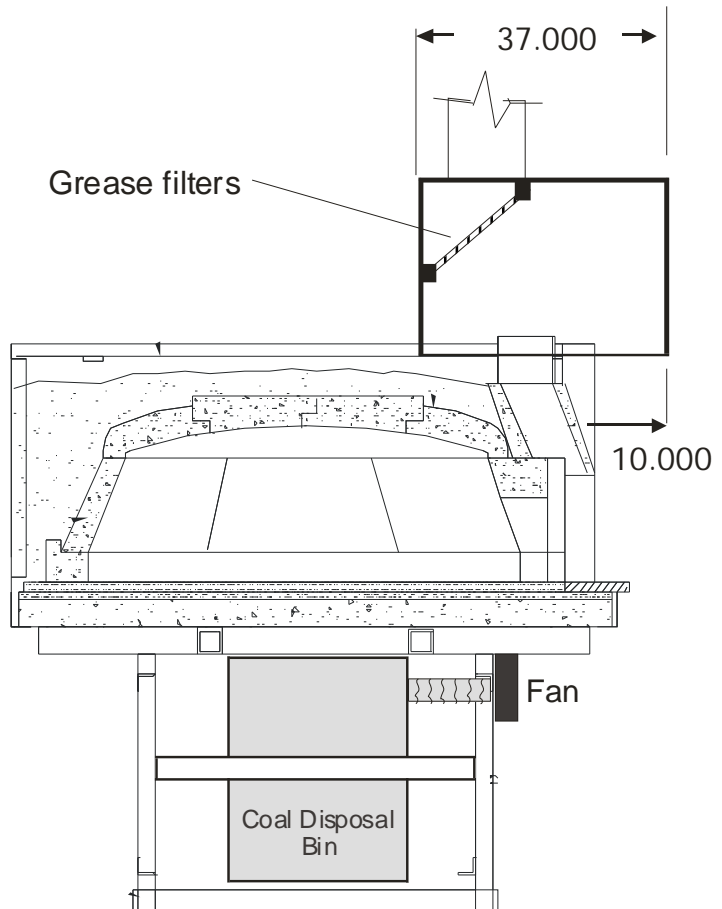
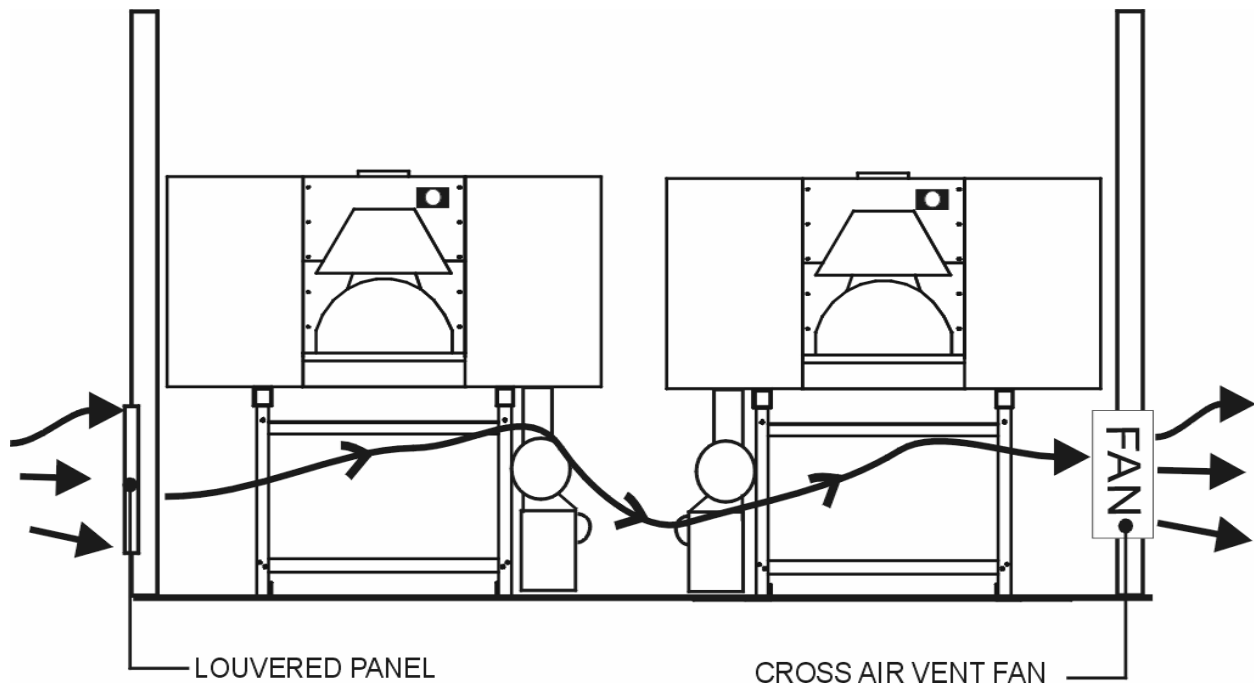

Figure 19

## Cross Air Vent Diagram

The cross air vent will provide air circulation to cool the bottom half of the oven and the surrounding enclosure. This will prevent the coal combustion air fans from overheating.

A thermostatic gable mount fan with should be used. (i.e. Model Master Flow PS2). Use at least a 20" x 20" louver on each side.



### COAL AND WOOD STORAGE

Coal and Wood storage shall not exceed a one-day supply where stored in the same room as the oven. Refer to NFPA 96 for storage requirements.